

# PANORAMAXX 2.5





QUICK START GUIDE .....	4
FUNCTIONS .....	6
SPARE PARTS .....	8
ENGLISH .....	11
FRANÇAIS .....	12
DEUTSCH .....	13
SVENSKA .....	14
ITALIANO .....	15
ESPAÑOL .....	16
PORTUGUÊS .....	17
NEDERLANDS .....	18
SUOMI .....	19
DANSK .....	20
NORSK .....	21
POLSKI .....	22
ČEŠTINA .....	23
中文 .....	24
MAGYAR .....	25
TÜRKÇE .....	26
日本語 .....	27
ЕЛМНИКА .....	28
БЪЛГАРСКИ.....	29
SLOVENSKY .....	30
SLOVENSKI.....	31
ROMÂNĂ .....	32
EESTI .....	33
LIETUVIŠKAI .....	34
LATVIEŠU.....	35
РУССКИЙ .....	36
HRVATSKI.....	37
GAEILGE.....	38
MALTI.....	39

1

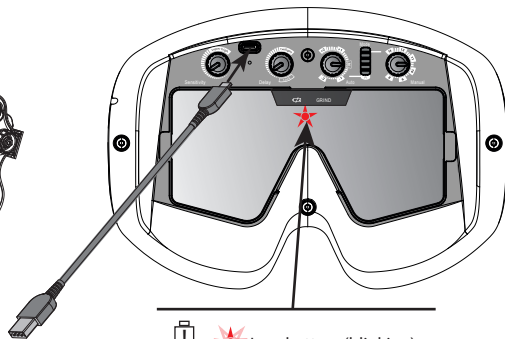

charging

- Low battery (blinking)
- Charging battery
- Fully charged battery

2

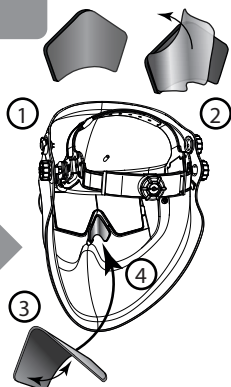

nose pad

6

grinding

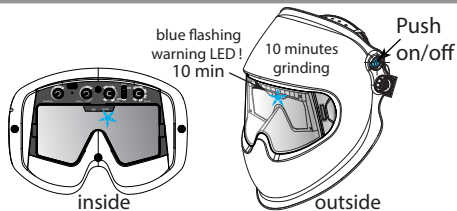

inside

outside

## QUICK START GUIDE

5

welding

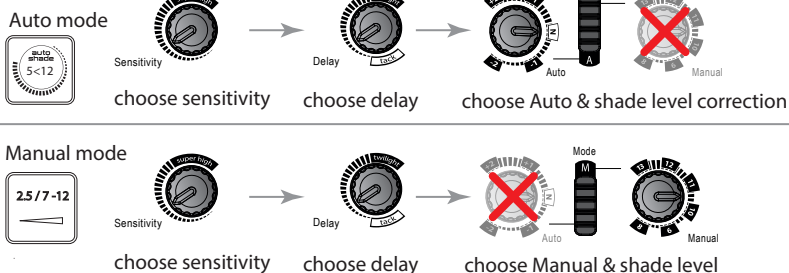

4



front/inside cover lens exchange

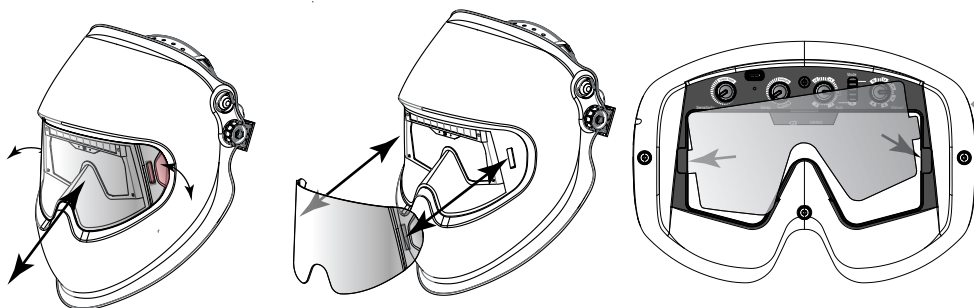

### 3 a head size adjustment

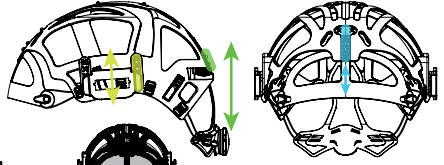
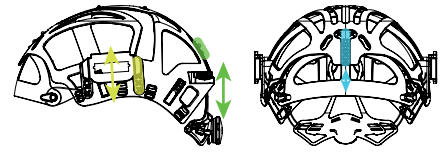
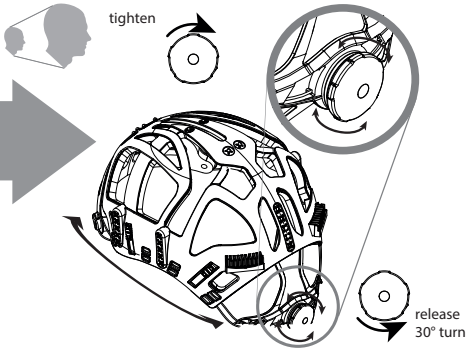

Link for instruction video on p. 42

### 3 b

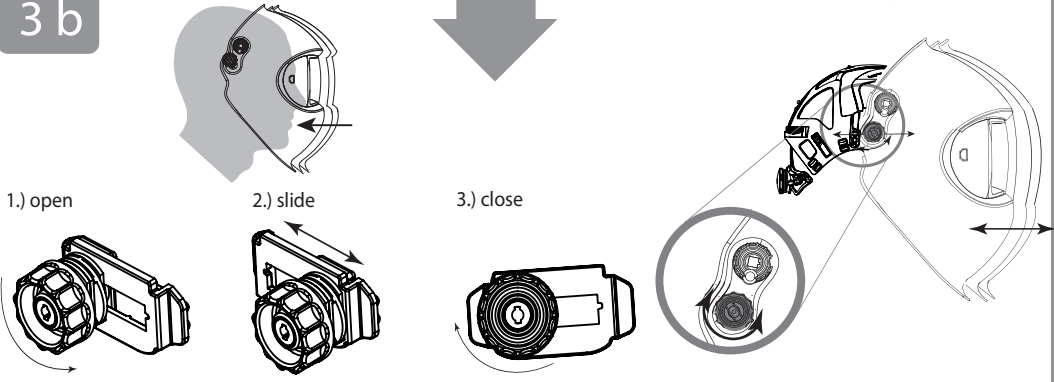

### 3 c

#### Excenter/ angle adjustment

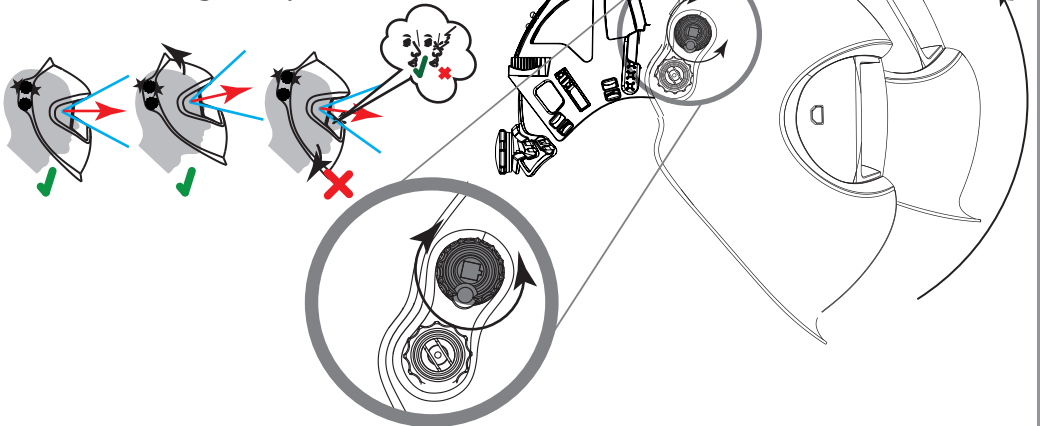

# I Sensitivity

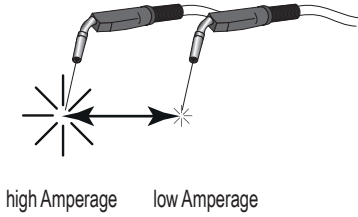

# welding

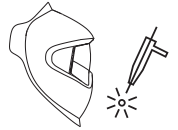

# Functions



# II Delay and Twilight Function

## contineous welding

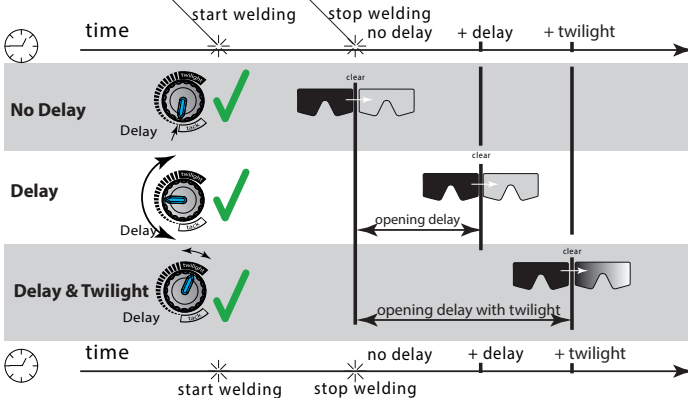
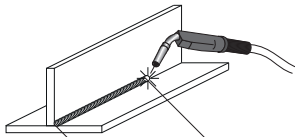

## tack welding

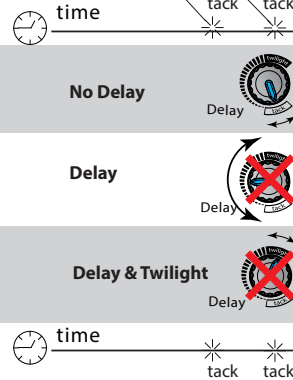
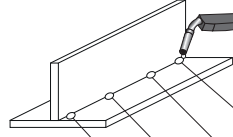

### III

## Auto mode



## Autopilot

individual shade level correction  $\pm$  2 shade levels

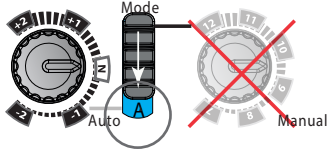
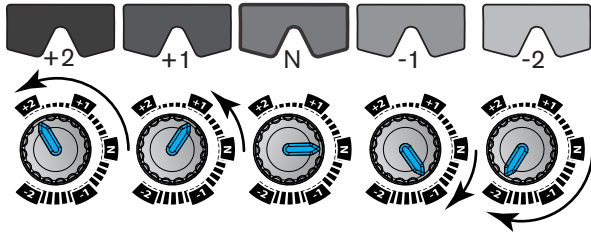

### IV

## Manual mode

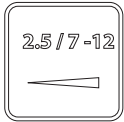

## Manual Shade level adjustment

shade level 7 up to shade level 12

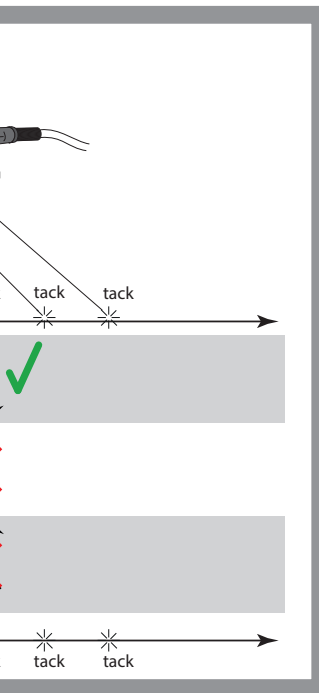
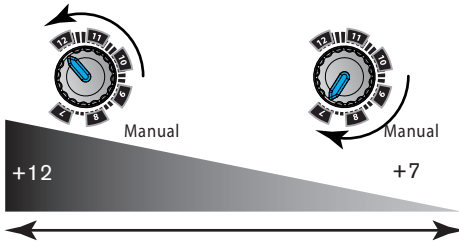
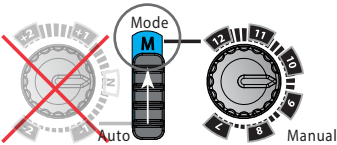

## V grinding

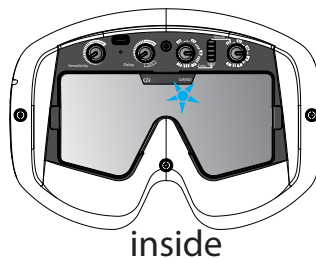
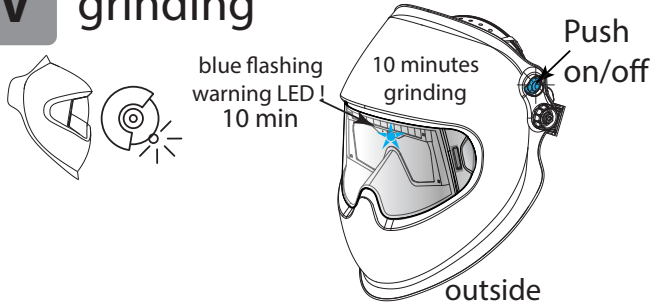

Comfort Pad

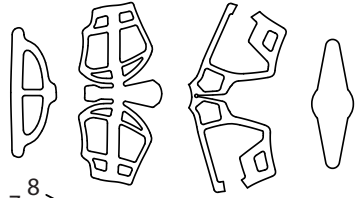

exchange of headband

sequential arrangement

helmet shell

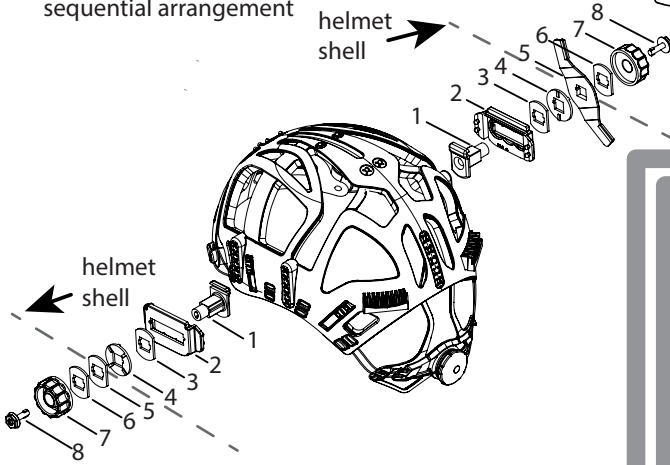

1

nose protection

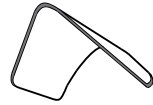

3

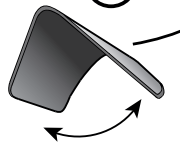

exchange of front cover lens & inside cover lens

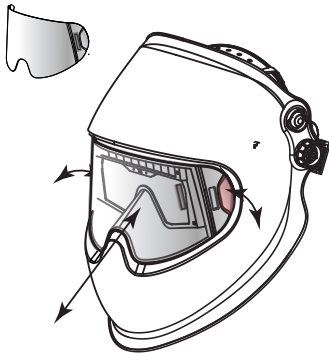

front cover lens

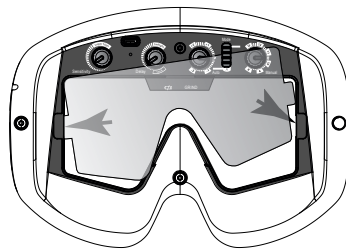
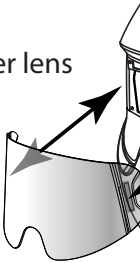

inside cover lens



nose protection

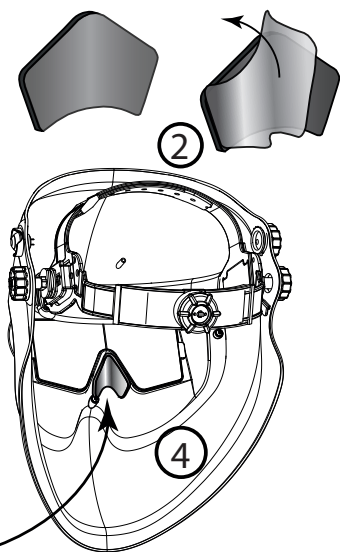

micro USB cable/ USB dust protection

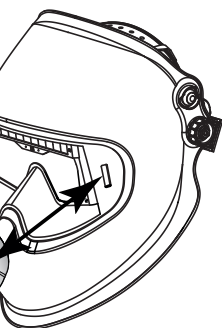
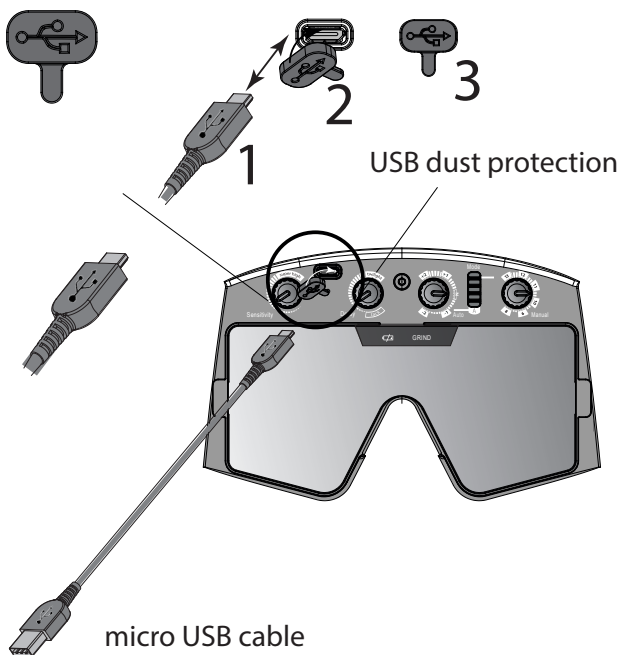







# Spare parts

see 3rd / 2nd last page

	SP01
	SP02
	SP03
	SP04
	SP05
	SP06
	SP07

Schutzstufentabelle EN169  
Shade level chart EN169

Tableau des niveaux de protection EN169  
Tabella dei livelli di protezione EN169

Process	Ampere																						
	1.5	6	10	15	30	40	60	70	100	125	150	175	200	225	250	300	350	400	450	500	600		
MMA 	8						9		10		11		12		13		14						
MIG heavy metals 							9		10		11		12		13		14						
MIG light metals, Al, Stainless 									10		11		12		13		14						
TIG 				8		9		10		11		12		13									
MAG 	8						9		10		11		12		13								
Plasma cutting 									9		10		11		12		13						
Micro plasma welding 	4	5	6	7	8	9	10	11	12														

Je nach persönlichem Empfinden kann die nächst höhere oder tiefere Schutzstufe verwendet werden.

According to the perception of the welder it is possible to use the next higher or lower shade number.

Selon la perception du soudeur il est possible d'utiliser un échelon de protection plus haut ou plus bas.

A seconda della sensibilità personale è possibile impostare il livello di protezione immediatamente superiore o inferiore.

Die auf dem Schweißerschutzfilter angebrachte Kennzeichnung bedeutet:

2.5/ 7-12  
2.5/ 5<12M  
Helmturfe  
Dunkelstufen  
Hersteller  
Optische Klasse  
Streulichtklasse  
Homogenität  
Blickwinkelabhängigkeit  
Nummer der Norm

OS / 1 / 1 / 1 / 1 / 2 EN379  
OS / 1 / 1 / 1 / 1 / 2 EN379

The marking on the welding filter indicates:

2.5/ 7-12  
2.5/ 5<12M  
Light shade  
Dark Shade range  
Manufacturer  
Optical Class  
Diffusion of light class  
Homogeneity  
Angular dependence  
Number of the standard

OS / 1 / 1 / 1 / 1 / 2 EN379  
OS / 1 / 1 / 1 / 1 / 2 EN379

Le marquage apposé sur le filtre de protection pour soudeur signifie :

2.5/ 7-12  
2.5/ 5<12M  
Echelon de protection à l'état clair  
Echelon de protection à l'état foncé  
Identification du fabricant  
Classe optique  
Classe de la diffusion de la lumière  
Homogénéité  
Angulaire dépendance  
Marque de certifications

OS / 1 / 1 / 1 / 1 / 2 EN379  
OS / 1 / 1 / 1 / 1 / 2 EN379

Il contrassegno riportato sul filtro di protezione per saldatore contiene i seguenti dati:

2.5/ 7-12  
2.5/ 5<12M  
Grado di protezione in stato chiaro  
Grado di protezione in stato scuro  
Identificazione del fabbricante  
Classe ottica  
Classe della diffusione della luce  
Omogeneità  
Angolare dipendenza  
Numero della norma

OS / 1 / 1 / 1 / 1 / 2 EN379  
OS / 1 / 1 / 1 / 1 / 2 EN379

Kennzeichnung Helmschale:

OS EN 175 B  
Hersteller  
Nummer der Norm  
Mittlere Stoßenergie  
Impatto media energia

Marking helmet shell:

OS EN 175 B  
Manufacturer  
Number of the standard  
Medium energy impact  
Impatto media energia

Marquages masque :

OS EN 175 B  
Identification du fabricant  
Marque de certifications  
Impacts moyenne énergie

Marccaggi maschera:

OS EN 175 B  
Identificazione del fabbricante  
Numero della norma  
Impatto media energia

Kennzeichnung Sicherheitsschutzscheibe:

OS 1 B EN 166  
Hersteller  
Optische Klasse  
Mittlere Stoßenergie  
Nummer der Norm

Marking safety protection lens:

OS 1 B EN 166  
Manufacturer  
Optical class  
Medium energy impact  
Number of the standard

Marquages écran de protection :

OS 1 B EN 166  
Identification du fabricant  
Classe optique  
Impacts moyenne énergie  
Marque de certifications

Marccaggi vetro di protezione:

OS 1 B EN 166  
Identificazione del fabbricante  
Classe ottica  
Impatto media energia  
Numero della norma

## Introduction

A welding helmet is an item of headgear that is used to protect the eyes, face and neck from burns, UV light, sparks, infrared light and heat during certain welding operations. The helmet consists of several parts (see spare parts list). An automatic welding filter combines a passive UV filter and a passive IR filter with an active filter whose light transmittance in the visible range of the spectrum varies depending on the light intensity in the welding arc. The light transmittance of the automatic welding filter has a high initial value (light state). After switching on the welding arc and within a defined response time, the light transmittance of the filter changes to a low value (dark state). Depending on the model, the helmet can be combined with a safety helmet and/or a PAPR (Powered Air Purifying Respirator) system.

## Safety instructions

Read the instruction manual before using the helmet. Make sure the finisher is mounted correctly. If faults cannot be remedied, the ADF must no longer be used. For further information, please contact your authorised retailer.

## Precautions & protective restrictions / risks

During the welding process, heat and radiation are released; this can cause eye and skin injuries. This product provides protection for the eyes and face. Your eyes are always protected against ultraviolet and infrared radiation when wearing the helmet, regardless of the protection level selected. Appropriate protective clothing must also be worn to protect the rest of your body. Particles and substances released during the welding process can trigger allergic skin reactions in persons with this disposition. With sensitive persons, skin contact with the head part can lead to allergic reactions. The welding helmet may only be used for welding and grinding and not for other applications. The manufacturer accepts no liability if the welding helmet is not used as intended or not used in accordance with the instructions for use. It's not allowed to apply Stickers or similar to the helmet. The helmet is suitable for all common welding processes, except gas and laser welding.

Please note the protection level recommendation according to EN169 on the wrapper. The helmet does not replace a safety helmet. Depending on the model, the helmet can be combined with a safety helmet. The design features of the helmet may affect the field of vision (no peripheral vision without turning the head) and the light transmittance of the automatic darkening filter may affect colour perception. As a result, signal lamps or warning indicators may not be seen. Furthermore, there is a risk of impact due to the larger contour (head with helmet). The helmet also impairs hearing and reduces the sensation of heat. Warning: For the overall marking of the safety class of the helmet, the lowest of all components used is always decisive. For use in extreme temperatures, pay attention to the appropriate labeling: FT, BT or AT. When wearing glasses, shocks can be transferred directly from the helmet to the head.

## Colour view

To increase convenience and safety, you can recognize colours with this welding helmet.

## Sleep mode

The ADF has an automatic switch-off function that increases the battery life. If less than 1 lux of light reaches the ADF for approx. 10 minutes, the ADF switches off automatically. To switch the cassette back on, the solar cells must be briefly exposed to daylight. If the ADF can no longer be activated or does not darken when the welding arc is ignited, the batteries must be replaced.

## Warranty & liability

The warranty conditions can be found in the instructions of the manufacturer's national sales organisation. Contact your authorised specialist retailer for more details. A warranty is only given for material and manufacturing defects. In the event of damage due to improper use, unauthorised intervention or use not provided for by the manufacturer, the warranty and liability are void. The liability and warranty are also void if spare parts other than those distributed by the manufacturer are used.

## Expected Lifetime

The welding helmet does not have an end-of-life date. The product can be used as long as no visible or invisible damage or malfunctions occur.

## Application (Quick Start Guide p. 4-5/ Functions p. 6-7)

Correct adjustment of the headband is very important for this product, because the benefits of the large field of view are only ensured if the headband is correctly adjusted.

- Headband head size/circumference. Adjust the upper adjustment strap to your head size. Push in the ratchet knob and turn until the headgear fits well but does not exert pressure. Make sure that your eyes are approximately in the centre of the field of vision. (p. 5 no.3a)
- Eye distance. You can loosen the locking buttons to adjust the distance between the cassette and the eyes. Position the helmet as close as possible to the eyes (the closer the ADF is to the eyes, the larger your field of vision will be). Adjust both sides equally without tilting. Then tighten the locking buttons again. (p. 5 no.3b)
- Helmet angle (excentre) The helmet angle can be adjusted using the rotary knob. Adjust the angle so that the nose does not touch the cut-out for the nose. Carefully perform a test to ensure that the helmet shell does not touch your nose, even when you nod (use the supplied nose pad to protect your nose). (p. 5 no.3c)
- Operating mode automatic/manual. You can use the slide switch to select the protection level adjustment mode. In automatic mode, the protection level is automatically adapted to the intensity of the arc by means of sensors (EN 379-2003 standard). In manual mode, the protection level can be set by turning the knob (p. 7 No. II + V)
- Protection level. Manual mode: In "Manual" mode, you can choose between protection levels 7 to 12 by turning the protection level control knob. (Protection mode correction is disabled in manual mode). (p. 7 No. IV)  
Auto mode: In Auto mode, the protection level is automatically adjusted and corresponds to protection level 5 > 12 according to EN 379 when the rotary knob is set to position "N". By turning the knob, the automatically set protection level can be corrected by up to two protection levels upwards or downwards depending on your personal preferences (the absolute minimum and maximum protection levels, 5 and 12, respectively cannot be undershot or exceeded, regardless of the correction setting). (p. 7 No. III)
- Opening time controller/delay. The opening time controller (Delay) (p. 6) allows you to select the opening time delay from dark to light. The rotary knob supports continuous adjustment from dark to light between 0.1 and 2.0 s (p. 6 no. II)
- Twilight effect. The twilight effect's smooth transition from dark to light offers even better protection of the eyes to prevent fatigue and irritation caused by afterglow from objects; it gives the eyes the time they need to acclimatise to the brightness (p. 6 no. II)  
CAUTION: For quick tack welding, do not set the rotary knob to the Twilight range. The "Tack" range with a minimal opening delay is best suited.

- Grinding mode. You can press the Grind button to set the ADF to grinding mode. In this mode, the cassette is deactivated and remains in light mode for 10 minutes. Active grinding mode is indicated by the blue LED flashing from the outside and by the reflection of the helmet's front cover lens on the inside. To switch off grinding mode, press the Grind button again. (p. 7 no. V)
- Sensitivity. With the sensitivity button the light sensitivity is adjusted according to the welding arc and the ambient light. This can be individually adjusted by turning the rotary knob. A very high light sensitivity is achieved in the "Super High" range; this guarantees darkening even with weak arcs. (p. 6 no. I)
- Sensors. This welding helmet has 5 sensors; 4 sensors detect the welding light and 1 sensor is responsible for detecting the light intensity (automatic mode) and the innovative Stay-Dark function.

## Cleaning and disinfection

The ADF and the finisher must be cleaned regularly with a soft cloth. Do not use strong cleaning agents, solvents, alcohol or cleaning agents containing abrasives. Scratched or damaged lenses should be replaced.

## Storage

The welding helmet must be stored at room temperature and low humidity. To extend the life of the batteries, store the helmet in a light environment.

## Replacing the front cover lens (p. 4 no. 4)

When changing the attachment disc, caution is required. Do not deform the helmet, as otherwise the welding filter can be damaged.

- The front cover lens be removed from the anchorage and removed by pulling the tab on the side backwards.
- Hook the new finisher into one side clip. Pull the finisher across to the second side clip and lock it in place. This manual action requires some application of pressure so that the seal on the finisher exhibits the desired effect.

## Battery/charging process (p. 4 no. 1)

The helmet has a high performance lithium polymer (LiPo) battery. Before using the battery for the first time, fully charge it with the supplied micro USB cable via a commercially available USB connector (not included). After charging, the micro USB socket on the helmet must be protected from dust and dirt with the protective cap. The battery is also charged by external light sources (ceiling light, welding light) via the solar cell. If the helmet is used frequently, the battery will very rarely need charging. We recommend charging the helmet completely every 6 months. If the battery is discharged, charging for approx. 15 minutes is sufficient for an operating time of approx. 8 hours.

## State of charge:

- Red flash: Battery is almost discharged (charge immediately)
- Orange permanently lit: Battery is charging
- Green permanently lit: Battery is fully charged

If the helmet fails to darken when the welding arc is ignited, please check the state of charge (press the grinding button: if the LED no longer flashes blue, the battery is completely discharged). If the ADF does not function correctly when the battery is charged, contact your authorised retailer.

A defective battery can be replaced by the manufacturer or an approved service centre.

## Troubleshooting

### ADF fails to darken

- Adjust the sensitivity (p. 6 no. I) → Deactivate grinding mode (p. 7 no. 5)
- Clean the sensors or front cover lens → Charge the battery (p. 4 no. 1)
- Switch off the opening delay - switch to "tack" for fast tack welding (p. 6 no. II)

### Protection level too bright

- In manual mode, select a higher protection level (p. 7 no. IV)
- In automatic mode, set the rotary knob to +1 or +2 (p. 7 no. III)
- Replace the front cover lens (p. 8 no. 4)

### Protection level too dark

- In manual mode, select a lower protection level (p. 7 no. IV)
- In automatic mode, set the rotary knob to -1 or -2 (p. 7 no. III)

### ADF flickers

- Adjust the position of the opening time control (delay) to suit the welding process (p. 6 no. II)
- Adjust the sensitivity controller to suit the welding process (p. 6 no. I) → Charge the battery (p. 4 no. 1)

### Poor visibility

- Clean the front cover lens or ADF
- In manual mode, adjust the protection level to suit the welding process (p. 7 no. IV)
- In automatic mode adapt the protection level correction to suit the welding process (p. 7 no. III)
- Increase the ambient light

### Welding helmet slips

- Re-adjust/tighten the headband (p. 5 no. 3a-3c)

## Specifications (We reserve the right to make technical changes)

Protection level	auto mode: 2.5 (light mode)	5 < 12 (dark mode)
	manual mode: 2.5 (light mode)	7 - 12 (dark mode)
UV/IR protection	Maximum protection in light and dark modes	
Switching time from light to dark	100µs (23°C/73°F)	70µs (55°C/131°F)
Switching time from dark to light	fast = 0.1 - 2.0 s with "twilight effect"	
Power supply	Solar cells, lithium polymer battery	
Weight	575 g / 20.3 oz	with PAPR: 745 g / 26.3 oz
Operating temperature	-10°C → +55°C / +14°F → +131°F	
Storage temperature	-20°C → +70°C / -4°F → +158°F	
Classification according to EN379	Optical class = 1	Homogeneity = 1
	Scattered light = 1 Dependence on angle of view = 2	
Approvals	CE, EAC, ANSI, AS/NZS, complies with CSA, pr ISO 16321 "WIG"	
Additional markings for PAPR version (notified body CE1024)	EN12941 (TH3 in combination with e3000 or e3000X, TH2 for versions with hardhat and e3000 or e3000X) EN14594 (Class 3B in combination with supplied)	

## Declaration of conformity

See the Internet address on the last page.

## Legal information

This document complies with the requirements of EU Regulation 2016/425 section 1.4 of Annex II.

## Notified body

For detailed information see last page.